

# TU 25 FM

Housing material

Cast iron

## Dimensions

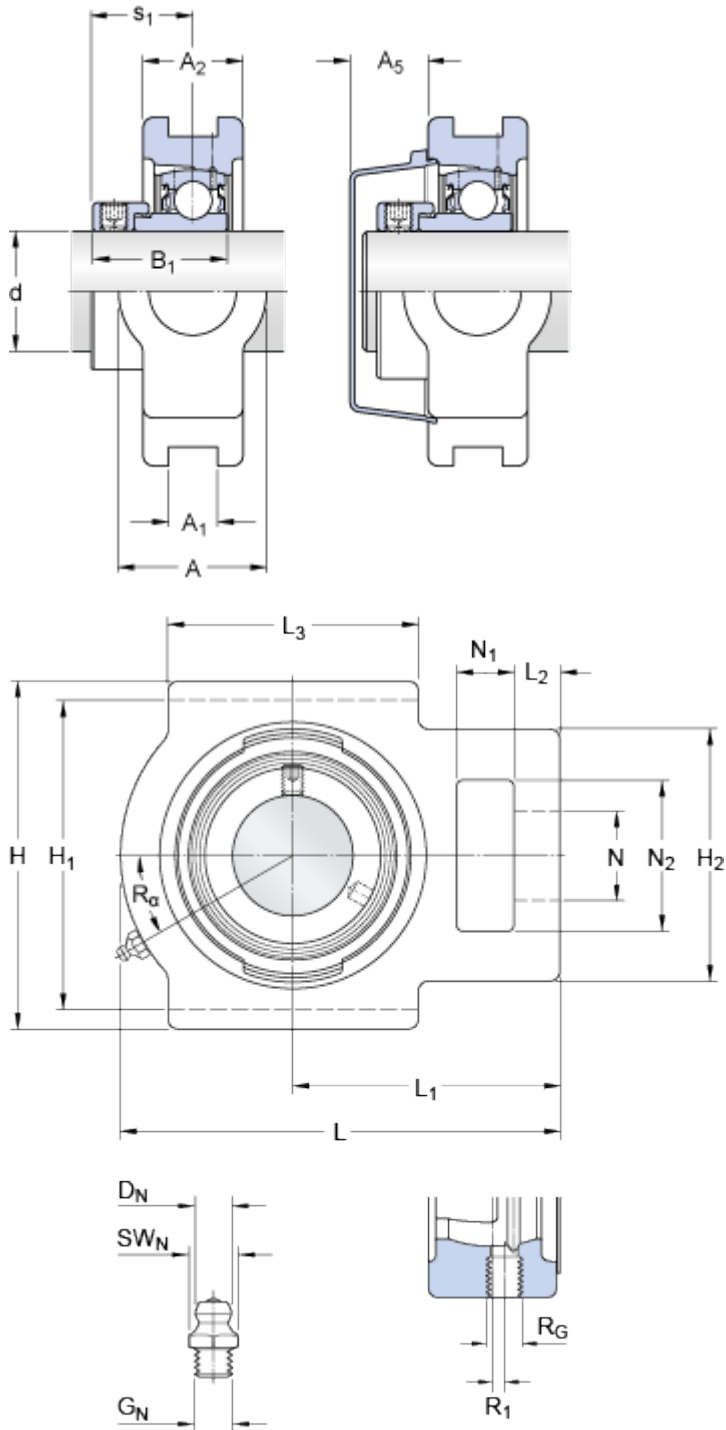

d	25	mm
A	34	mm
A <sub>1</sub>	13.5	mm
A <sub>2</sub>	25	mm
A <sub>5</sub>	18	mm
B	21.5	mm
H	91	mm
H <sub>1</sub>	76	mm
H <sub>2</sub>	53	mm
L	100	mm
L <sub>1</sub>	64	mm
L <sub>2</sub>	10	mm
L <sub>3</sub>	52	mm
N	19	mm
N <sub>1</sub>	16	mm
N <sub>2</sub>	33	mm
s <sub>1</sub>	23.5	mm

### Grease fitting

D <sub>N</sub>	6.5	mm
SW <sub>N</sub>	7	mm
G <sub>N</sub>	1/4-28 SAE-LT	

### Threaded hole

R <sub>G</sub>	1/4-28 UNF	
R <sub>1</sub>	2	mm

**Calculation data**

Basic dynamic load rating	C	14	kN
Basic static load rating	C <sub>0</sub>	7.8	kN
Fatigue load limit	P <sub>u</sub>	0.335	kN
Limiting speed with shaft tolerance h6		7000	r/min

**Mass**

Mass bearing unit		0.85	kg
-------------------	--	------	----

**Mounting information**

Grub (set) screw	G <sub>2</sub>	M6x0.75	
Hexagonal key size for grub screw	N	3	mm
Recommended tightening torque for grub screw		4	N·m

**Appertaining products**

Housing	TU 505 M
Bearing	YET 205

**Appropriate products**

End cover	ECY 205
-----------	---------